

CARGO FLOOR[®] the moving floor for winners!



The fastest...
The lightest...
The strongest...
Simply the best!!



Efficient loading and unloading

Cargo Floor B.V. is the global leader in multifunctional horizontal (un)loading systems. The Cargo Floor system is based on a “work smarter, not harder” principle designed to facilitate fast, safe, and efficient transport through floor movement. Rather than burdensome, time-consuming, and sometimes dangerous “lift-and-carry” methods, Cargo Floor technology enables the contents of every trailer to be loaded and unloaded in a matter of minutes by moving the trailer floor under the product.

Development

Cargo Floor prides itself on its extensive field experience (>30 years) collaborating with OEM engineers to craft and manufacture the best possible (un)loading systems. Cargo Floor technology relies on this experience as well as market feedback from transport companies, material handling experts, logistic managers, and its customers to ensure that Cargo Floor is always able to develop the most reliable, strongest, and most durable system for every application, while still being lightest moving floor system in the world! By using the very latest technology and state of the art components, Cargo Floor strives to be the most innovative manufacturer and supplier of moving floor systems worldwide. All Cargo Floor drive units are powered by hydraulics, mechanically driven by internal valves in order to prevent atmospheric and external conditions (like dust, dirt, or grime) from impacting each system’s operation and performance.

The system allows for a wide variety of bulk materials and other goods to be effortlessly transported, including pallets, bales, and even paper reels! The enormous success of Cargo Floor’s hydraulic-operated drive units is based on a simple and easy to install system that is generally suitable for all types of trailers, equipment, and freight. Cargo Floor’s standard system (CF500) can handle most transport applications, however, Cargo Floor’s engineers have vast experience crafting all kinds of dedicated applications for specialized or unique transport needs.

Value

Cargo Floor systems are not only designed to move product faster, safer, and smarter, but also cheaper than the more conventional options. Countless factors must be considered to cost-effectively and efficiently transport goods and materials in the modern economy. Cargo Floor systems provide substantial benefits over conventional (un)loading methods by capitalizing on new efficiencies across all major factors, including maximum volume, lower tare weight, lower operational cost (maintenance free), durability, sustainability, as well as human safety and environmental friendliness. The Cargo Floor drive units are designed to meet all of these requirements and more in order to achieve a timely and favourable return on any capital investment.

Pre assembled and tested drive unit

- ① The drive units are standard preserved against rust by the best Cathodic Dip Painting (CDP) process
- ② Solid piston rod guidance
- ③ Double chromated solid piston rods
- ④ High pressure filter is standard
- ⑤ All hydraulic components are of the highest quality and are fully CNC produced
- ⑥ Hydraulic piping (no hoses)
- ⑦ Pressure gauge
- ⑧ The control valve is positioned at the outside of the trailer for easy access
- ⑨ Common-rail technology

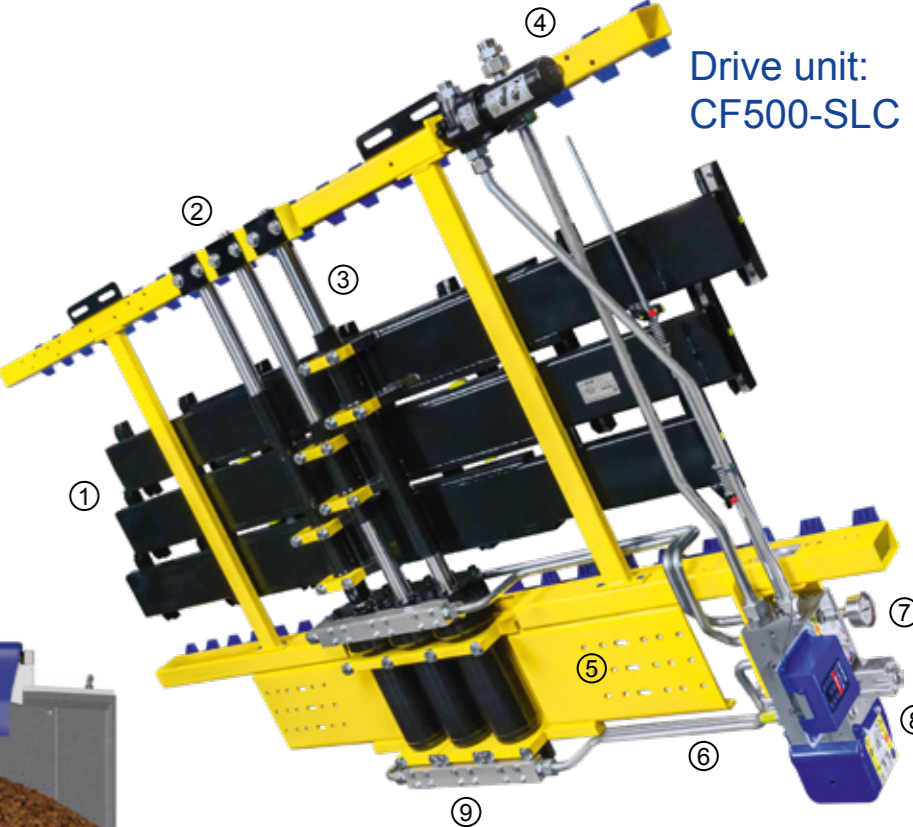

Applications

The standard Cargo Floor 'moving floor' System is ideally suited to the transport of almost all common products. In addition to the standard system, Cargo Floor also has a range of different drive units and floor sections available for special applications. The range of sections encompasses narrow or broad and ribbed or smooth sections in a variety of thicknesses. Sections are also available in a variety of materials (aluminum/steel/compo- site/plastic, or any combination of these materials).

Cargo Floor has proven its quality in the transport of materials such as:

- | | | |
|-------------------|-----------------------|-----------------------------|
| • bulk materials | • straw (bales) | • salt |
| • RDF (fluff) | • maize | • chalk |
| • biomass | • grain | • coal |
| • recyclables | • potatoes | • waste paper |
| • domestic waste | • carrots | • rolls of paper |
| • green waste | • tapioca | • aluminum scrap |
| • wood chippings | • milk powder | • cargo (bales / bags) |
| • sawdust | • coffee beans | • big bags |
| • bark | • soya beans | • pallets |
| • logs of wood | • alfalfa | • slaughter waste |
| • potting soil | • sugar beet and pulp | • sewage sludge |
| • peat | • animal feed | • compressed bales |
| • clay | • manure | • all agricultural products |
| • bleaching earth | • fertilizer | • etc. |

When used in combination with special alu heavy duty or steel slats the Cargo Floor can also be used to transport more abrasive products (ask your dealer):

- | | | |
|--------------|----------------------|--------------------------------|
| • glass | • household waste | • vegetables and fruit |
| • gravel | • demolition waste | • steel scrap |
| • ore | • construction waste | • all other abrasive materials |
| • car wrecks | • sharp sand | |

Automatic roll up tarp

For special applications a roll up tarp could be a good solution to avoid damage to the product or the floor profiles.



SAFE AND MULTIFUNCTIONAL



Combined loads bulk + palletized!

Drivable with forklift!

Loading & unloading!

Controlled unloading!

Horizontal no tipping!

How it works

Multifunctional

The Cargo Floor 'moving floor' System is a multi-functional, horizontal loading and unloading system for the fast and efficient transport of almost any product.



Scan QR to see how it works in real motion

Ideal for

It is ideal for unloading a wide variety of bulk products, which are typically loaded from above and unloaded horizontally from the rear. It works in two directions and can be used to both load and unload product.



Efficiency

Efficiency of loading and unloading (packed) cargo is determined mainly by the weight distribution of the cargo over the floor area of the Cargo Floor. Uneven weight distribution will reduce efficiency and may even cause the cargo to only move back and forth during the power stroke of the system. Supports can be used in these scenarios to improve weight distribution across the floor.

Intelligent Remote Control Module (IRCM)



Optional

 IRCM pressure sensor 0-250bar Part no. 2404547	 IRCM heat sensor 90°C Part no. 6402029
--	--

Free IRCM app

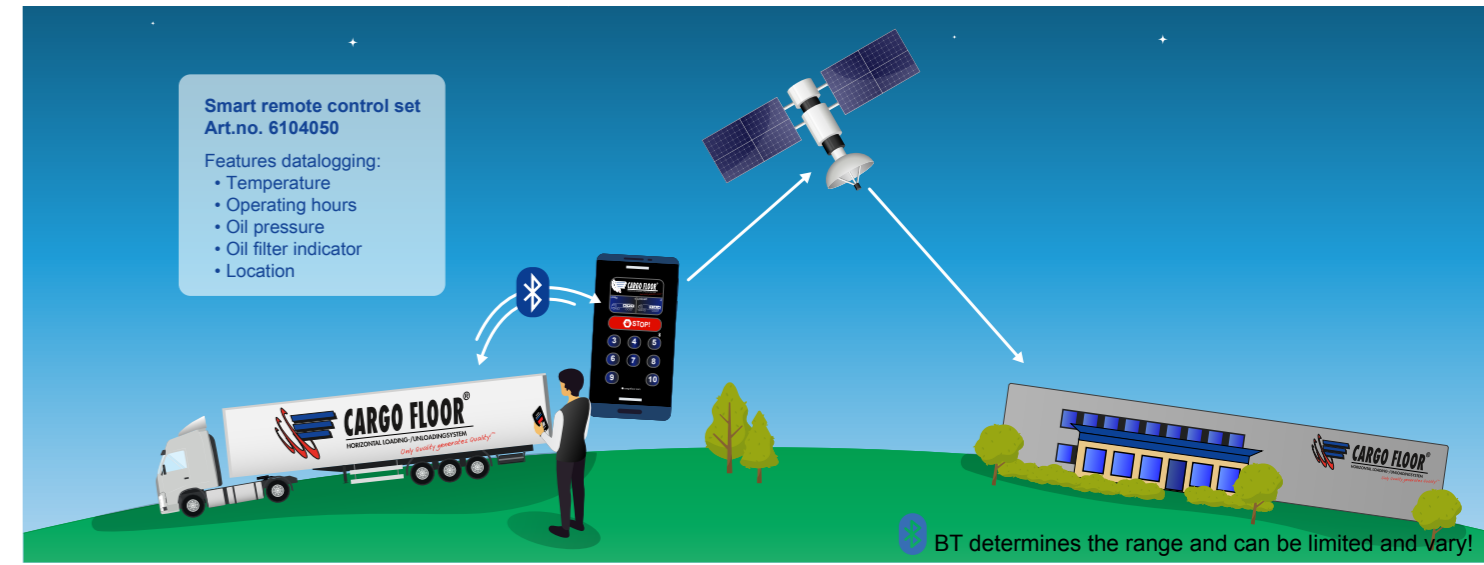
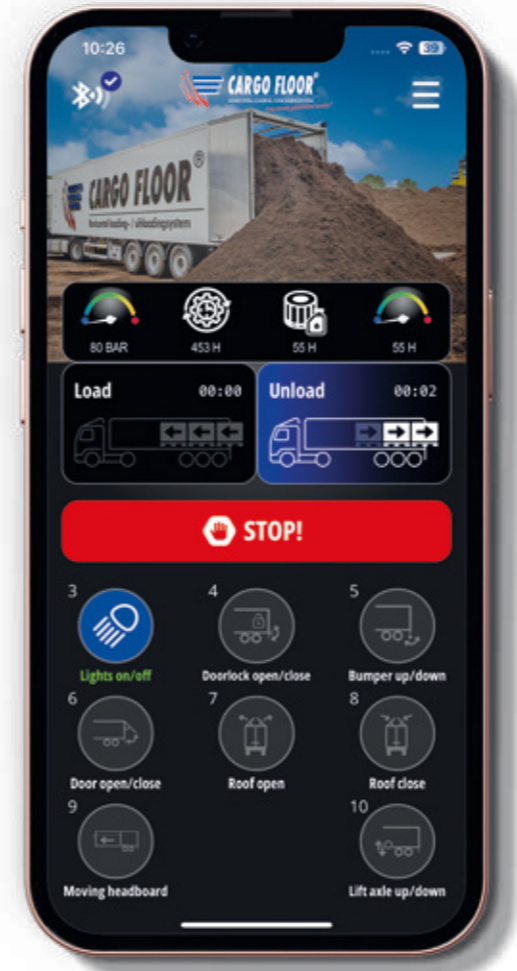

The Cargo Floor systems can be provided with an Intelligent Remote Control Module (IRCM) in which many functionalities have been included. Depending on the options, the following items can be operated via a waterproof (IP67) touch sensitive operating panel. Developed entirely in house by Cargo Floor.

Standard features













Extension module for other features
 The Intelligent Remote Control Module can, via Bluetooth, easily be connected with an extension module, to operate many extra functions remotely with the same Remote Control or mobile phone.

Extra functions eg.:



- Worklights
- Axle lift
- Roof operation (open/close)
- Hydraulic tailgate (open/close)
- Retraction moving headboard

(i) Intelligent

The IRCM is standard featured with data logging memory and real time viewing, s.a:

-   Oil temperature monitoring
-   00:00 Operation hours
-   Oil pressure monitoring
-   Oil filter indicator
-   Vehicle location, real time monitoring and support

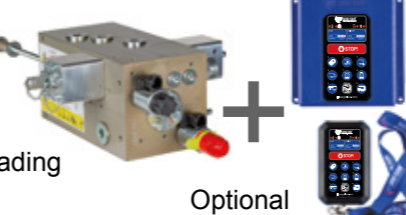
Control options

<p>E-control</p> <p>Full automatic Unloading/stop/loading</p> 	<p>B-control</p> <p>Semi automatic Unloading/stop/loading</p> 	<p>A-control</p> <p>Manually Unloading/stop/loading</p> 
--	--	--

Subdeck and Guidance

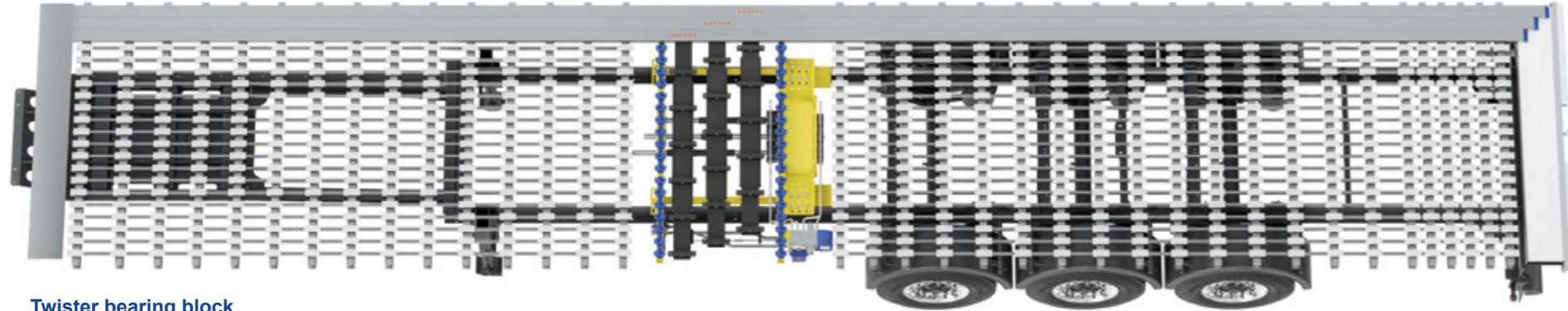

Twister bearing block
easy installation without any tools to the subdeck 25x25 (1"x1") tube or U profile.

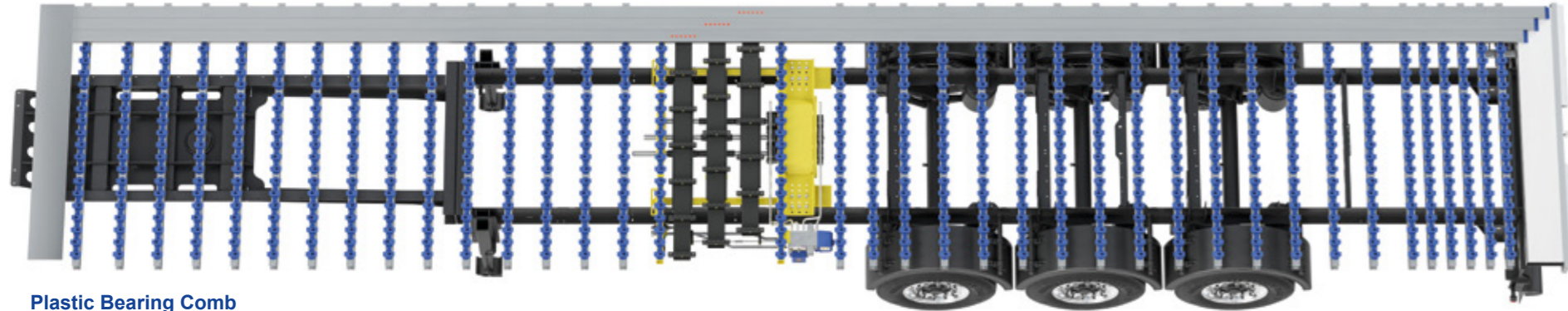

Plastic Bearing Comb
Can be easily mounted with screws, rivets or nailgun shots directly on top of aluminum- or steel crossmembers. No subdeck required!

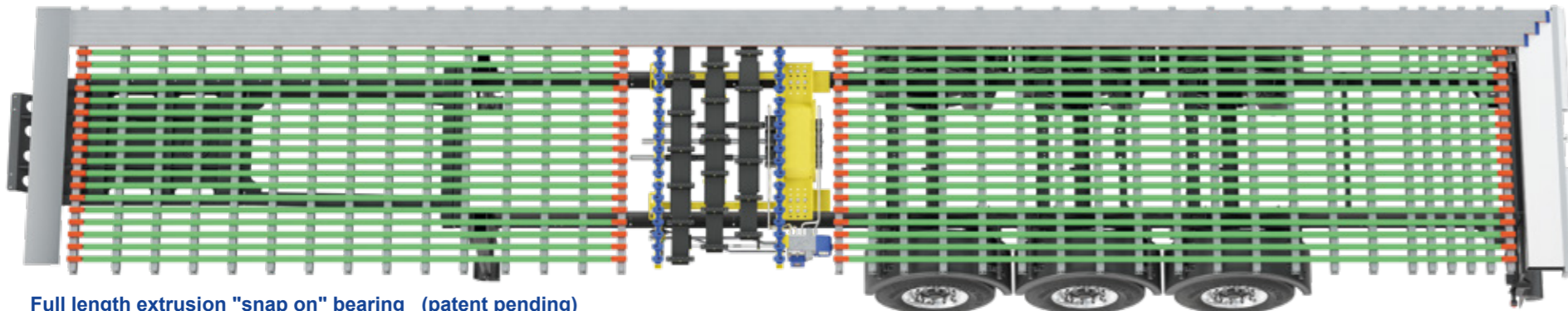

Full length extrusion "snap on" bearing (patent pending)
This full length extrusion "snap on" bearing is very easy vertically mounted from above on the aluminum subdeck rail (absolutely no tools required). The aluminum rail can be easily mounted by welding, screws, rivets or nailgun shots directly on top of aluminum- or steel crossmembers.

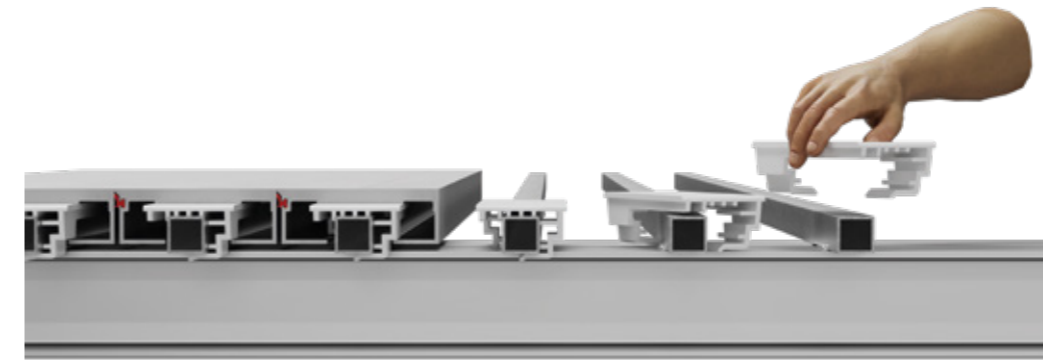

Twister bearing block

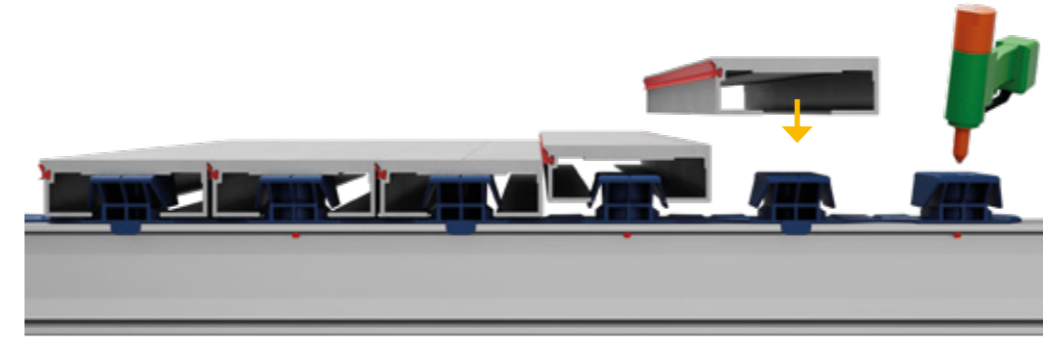

Plastic Bearing Comb

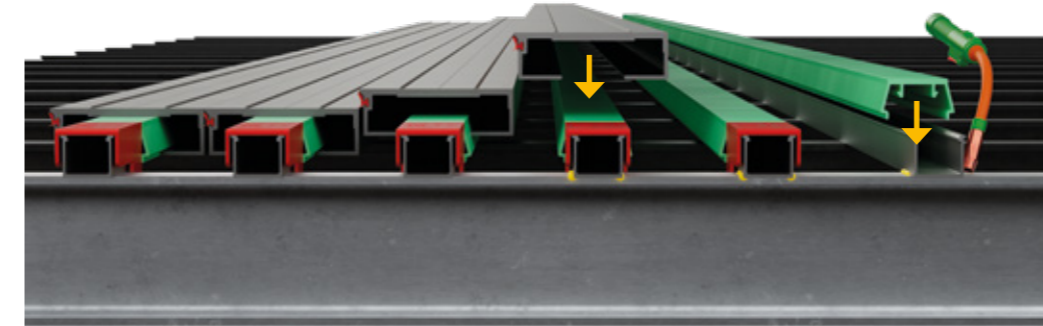

Full length extrusion "snap on" bearing (patent pending)

Various slat profile mounting

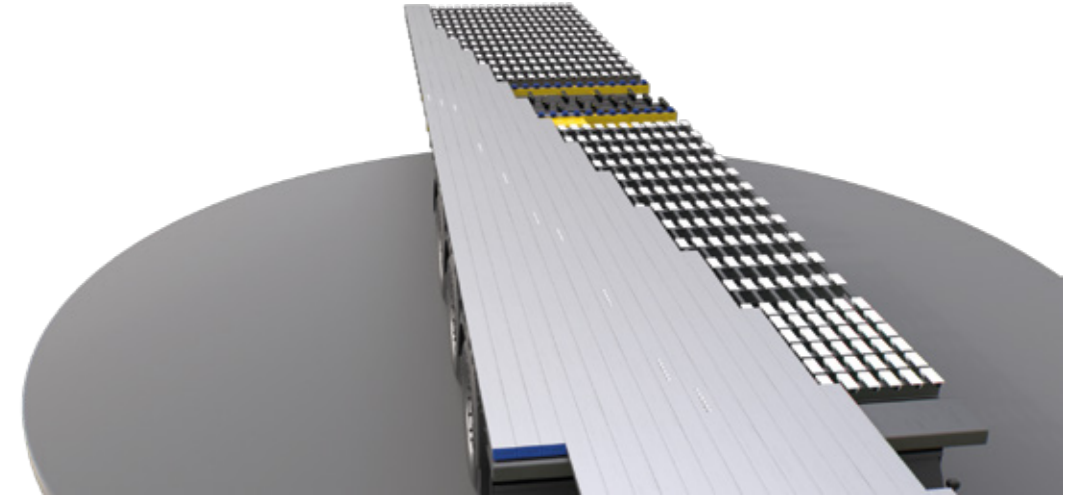

Sliding in horizontally from the rear

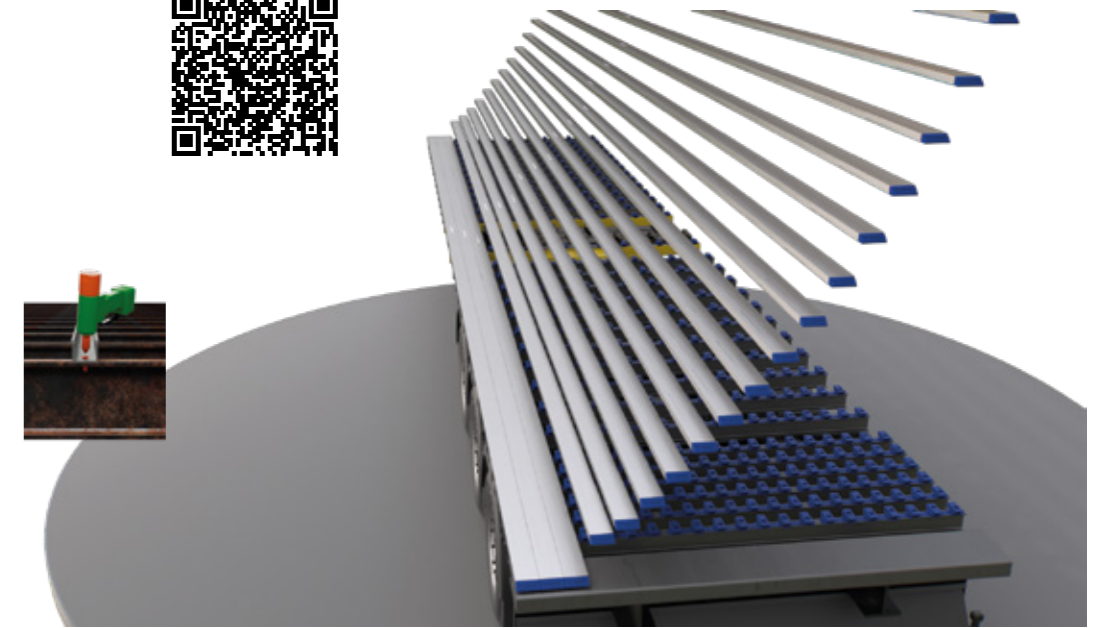

Vertically downwards from above

LP-series 100% Leak Proof

The CF3LP Speedster, the epitome of innovation in the moving floor industry. Our 100% Leak Proof system sets a new standard for efficiency and reliability, making it the fastest solution available on the market today.

Unrivaled Speed: Experience unmatched efficiency with the CF3LP Speedster. Its world's fastest leak proof waste unloader! The operation ensures seamless unloading and maximizing productivity.

Compact yet Strong: the compact design ensures an absolute minimum loss of compartment space, there is no other LP system in the world who can haul more m3 volume. The Speedster boasts exceptional strength, it can handle heavy loads with ease while remaining incredibly lightweight and compact, allows more - paid - cargo to be transported.

Easy Installation and Maintenance: Installing the Speedster system is a breeze, and maintenance is even simpler, the drive system is located completely outside the cargo space. Its modular design allows for easy removal and replacement of cylinders individually, minimizing downtime and keeping operations running smoothly.

Decades of experience: The CF3LP Speedster is the culmination of years of global experience in the leak-proof market. Trust in the proven track record of excellence and let the Speedster elevate your transportation capabilities to new heights.

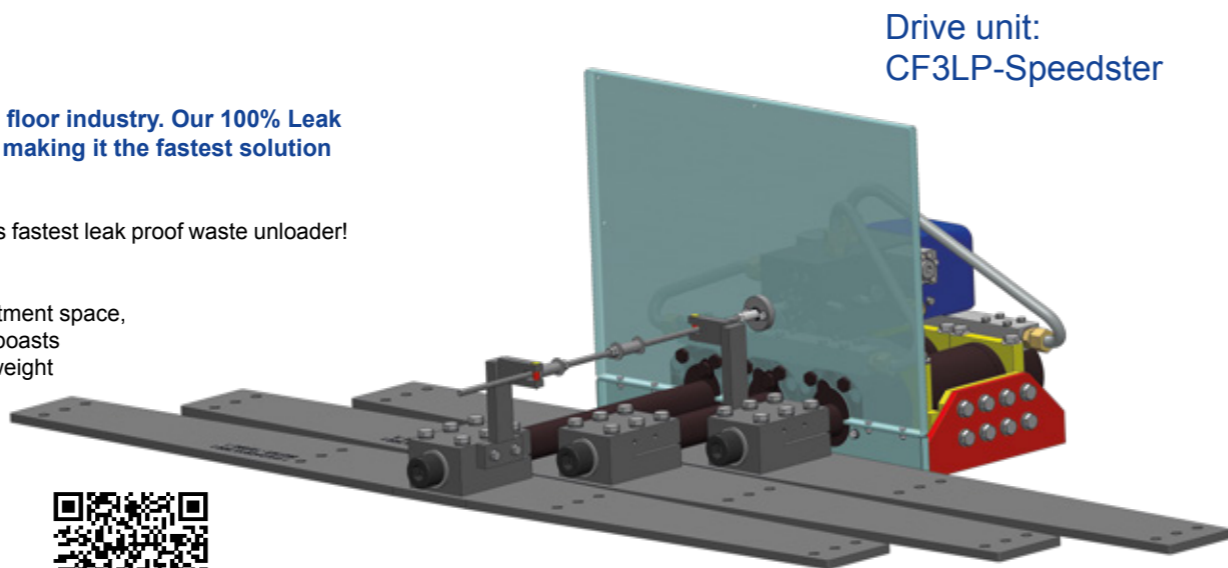

Drive unit:
CF3LP-Speedster



Speedster

- 👉 world's fastest LP waste unloader
- 👉 world's largest m³ volume
- 👉 100% Leak Proof
- 👉 highest payload
- 👉 light weight



LP-series 100% Leak Proof

Drive unit: CF3LP-Speedster

LR-series Leak Resist

Cargo Floor is committed to protecting the planet and has developed the Leak Resist floor to prevent products leaking onto the road and contaminating the environment. Cargo Floor has over 25 years' experience with various unique Leak Proof and Leak Resist floor solutions.

By using the Cargo Floor LR-series, liquid-containing "waste" products can be transported in a safe and environmentally sound manner.

Cargo Floor has developed a unique slide-in subdeck design where the standard Cargo Floor drive unit is mounted UNDER the floor. This subdeck design has proven to be the ultimate solution for preventing leakage onto the road while providing superior stability and impact resistance. The simple 'slide-in' system of the subdeck profiles makes installation fast and easy in both new and retrofit applications.

The subdeck can be mounted on aluminum crossmembers by welding or popriveting and can also be mounted on steel cross members by riveting. Sealing can be done either by welding or using kit.

A solid bearing is installed across the entire length of the trailer directly under the moving floor profiles.

Important Note The LR-series is resistant to leaks and is NOT designated as 100% leak proof because of the undermount drive unit construction. Any leakage that may occur should only be possible at the joint between the drive system and the floor profiles. A collector bin can be installed to prevent any spilling on the floor.



Drive unit:
CF500-LR



CF500-LR

- 👉 leak resist
- 👉 high impact resistant
- 👉 maximum volume
- 👉 light weight



LR-series Leak Resist

Drive unit: CF500-LR

Moisture collector bin

Various subdeck solutions for LP- and LR-series

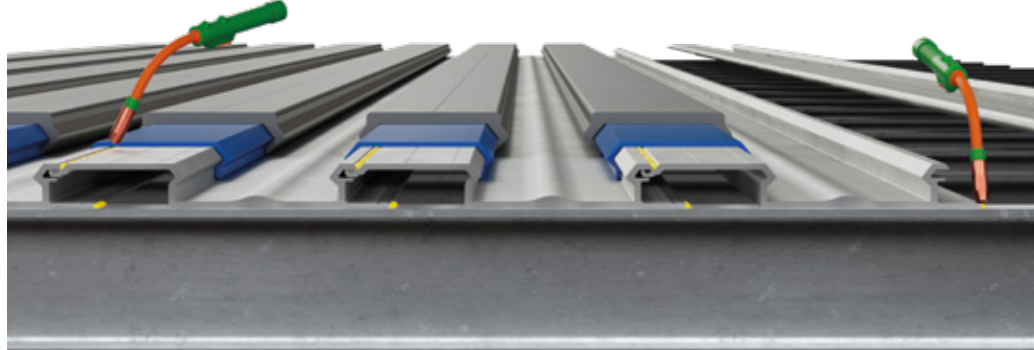

"Slide in" subdeck profiles welded on aluminum crossmembers (alternatively rivited), sealed by full length welds.

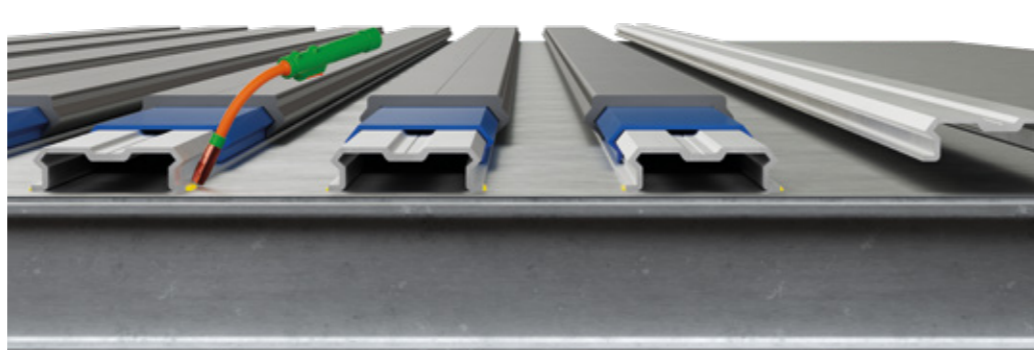

Loose aluminum subdeck profiles welded on an aluminum smooth plate.



"Slide in" alu subdeck profiles rivited on steel crossmembers and sealed with sealant.



Loose aluminium subdeck profiles rivited on a steel box section welded to a steel plate.

Waste transferring



Ultra Light-series

This unique lightweight Cargo Floor system has been developed especially for simple installation in trucks, drawbar trailers, containers and interchangeable containers (demountables).

A few characteristic of the CF100-SLL system:

- Lowest installation height possible in combination with 80 mm. cross member
- Extremely low intrinsic weight of the power unit
- Floor speeds between 0 – 2.5 meters / min.
- The entire hydraulic drive is controlled solely by mechanical/-hydraulic means
- The pre-assembly of the cylinders, pipes and valves in a compact frame ensures a very simple and rapid installation
- Sub-frame may be dropped, in which case the hydraulic drive can be integrated in your own structure (for example aluminium/composite)
- Enables the maximum cargo volume to be utilized
- Suited for use as an autonomous metering silo
- Maximum load 20 tons
- Maximum floor length 9000 mm
- Passivated hydraulic piping

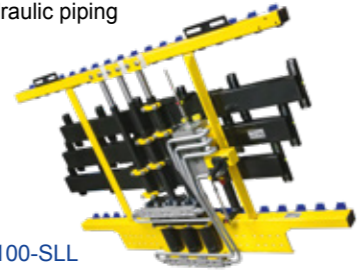

Drive unit: CF100-SLL



HighSpeed drives for agricultural products

Cargo Floor has world's fastest unloading drive unit available; the CF500-HS HighSpeed drive.











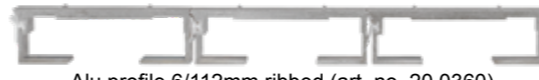















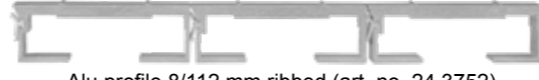







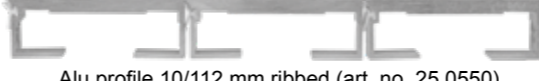



































The Driveunit will unload product with a theoretical speed of 4,4mtr/min. (double the normal speed) depending on the flow rate of the necessary special pump set up. (see page 23 for the technical specs of the CF500-HS HighSpeed drive)



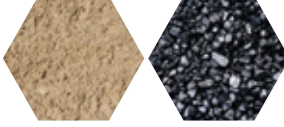
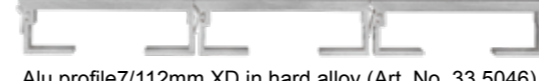











































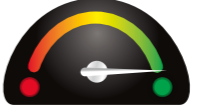









Drive unit: CF500-HS



Profile survey: standard profiles

	Profile type	Multi-functionality	Leak resistance	Cleanability	Pallet-/bales transport	Drive over with a fork lift truck	Impact resistance	Weight approx.
 <p>The ultimate standard Alu profile 6/112mm ribbed The balanced weight and strong proportions makes this profile suitable for almost every product that needs to be transported. The ribs are only meant to provide traction and guidance to the product (mainly to avoid twisting of pallets). The unique shaped seal can be pulled in the profile to avoid leakage and protect the transported product against road dirt and water splash. The seal itself is also protected by the shape of the profile. To seal both sides of the moving floor surface one double seal profile is provided. With this double seal profile the floor can be easily turned after several years, to extend the life time. This profile can be mounted on most of the plastic bearing blocks and sub decks available. The plastic bearings underneath are protected by and enclosed within the shape of the aluminum profile, this gives an excellent stability to the floor profile and is also protected against street dirt.</p>	 Alu profile 6/112mm ribbed (art. no. 20.0360)							X
 <p>Completely smooth for product protection Alu profile 6/112mm smooth This smooth profile is almost identical with regards to the shape and weight to the 6 mm standard profile, with the exception that the two top ribs have been omitted. This has been done in order to prevent damages to products. If the floor has been mounted correctly this profile has the same excellent qualities as the 6 mm standard profile. This profile is very suitable for the transport of paper reels and agricultural products.</p>	 Alu profile 6/112mm smooth (art. no. 22.0547)							X + 0 kg
 <p>The compromise between weight and impact Alu profile 8/112 mm ribbed This "in between" profile has the same shape and qualities as the 6 mm standard profile. The only difference is that this profile is 2 mm thicker. This results in even more stability, better suitable for more intense use whereas the risk of deformation of the profile due to product impact onto the floor or driving over the floor with a fork lift truck is reduced. If one can overlook the weight increase we certainly would advise this profile. This profile is also available in a smooth version: Alu profile 8/112 mm smooth (art. no. 37.1505).</p>	 Alu profile 8/112 mm ribbed (art. no. 24.3752)							X + 160 kg
 <p>The heavy duty allrounder Alu profile 10/112 mm ribbed Impact, wear resisting and driving over this profile, nothing is too much for this profile. The profile itself has the same specifications as the 6 mm standard profile but this profile is 4 mm thicker can be used for the transport of almost any product or machine. Only the extra weight and extra cost of this profile could make you choose another profile. This profile is also available in a smooth version: Alu profile 10/112 mm smooth (art. no. 27.0552)</p>	 Alu profile 10/112 mm ribbed (art. no. 25.0550)							X + 310 kg
 <p>SLP the Semi Leak Proof profile Alu 8/112mm SLP ribbed This is a profile, as the name already mentions, which is almost leak proof. The profile is just as all round as the 8 and 10 version but as an extra feature: moist products cannot leak through the floor directly. Liquids leak into a special gutter. This gutter can be exchanged and can be simply removed out of the floor for cleaning when necessary. This profile does require a small adjustment to the head board. The profile is very suitable for the transport of fine or moist products that may not leak onto the surface when loading, driving or unloading. However it is never meant as leak proof, for this we recommend the LR-/LP series.</p>	 Alu 8/112mm SLP ribbed (art. no. 72.2988)							X + 180 kg
 <p>A dedicated Heavy Duty profile Alu profile 8-20/112 mm HD This profile is a dedicated profile. This means that the profile is especially designed for the transport of special (mostly extreme) products. Because of the two protruding round merlons this profile has a very high impact resistance and the special round shape makes it easy to clean. Moist and dusty parts flow back into the barrel shape, so moist, mud and dust can simply be drained to the outside and almost no leakage through the floor occurs. This also protects the seal. Because of the low weight a perfect pay load ratio remains. The profile is less suitable for the transport of pallets and packaged goods.</p>	 Alu profile 8-20/112 mm HD (art. no. 31.1197)							X + 370 kg
 <p>The extreme dedicated Heavy Duty Impact profile Alu profile 8-18/112 mm HDI This profile is a dedicate profile. This means this is a profile that has been especially designed for the transport of special (mostly extreme) products. Because of the three protruding round merlons this profile has an unbelievable high impact resistance, that can be compared with construction steel. The round shapes makes it easy to clean. Moist and dusty parts flow back into the channels, so moist, mud and dust can simply be drained to the outside and almost no leakage through the floor occurs. This also protects the seal. Because of the low weight a perfect payload ratio remains. The profile is less suitable for the transport of pallets and packaged goods.</p>	 Alu profile 8-18/112 mm HDI (art. no. 30.0695)							X + 600 kg
 <p>A unique aluminium profile with extra protection and sealed by overlap Alu profile 11/112 (119) mm smooth overlap This 11/112 (119) mm smooth overlap alu. profile is especially developed for those applications where no load may leak through between the floor profiles onto the ground. This does not mean that the floor is liquid-tight or will not leak.  Warning! Incorrect use can result in materials accumulating under the overlap lip, which could cause the profiles to tilt and in the worst case scenario the floor could jam.</p>	 Alu profile 11/112 (119) mm smooth overlap (art. no. 67.6315)							X + 380 kg
 <p>Xtreme Durable 'hard alloy' aluminum floor profile Alu profile 7/112mm XD in hard alloy This unique 7/112 XD 'X-treme Durable' alu. floor profile is made out of a special developed hard alloy for transport applications which do high frequency loading and unloading as well as the transport of products which have a higher abrasiveness. It is also the extreme and high grade alternative for steel floor profiles, especially if multi functionality (pallet transport, flat floor surface, the ability to drive over the floor with a fork lift truck) and weight are of essential importance for you. <u>The Lightest, Strongest, most wear resistant!</u></p>	 Alu profile 7/112mm XD in hard alloy (Art. No. 33.5046)							X + 120 kg

Profile survey: Bulkmove wide profiles

	Profile type	Multi-functionality	Leak resistance	Cleanability	Pallet-/bales transport	Drive over with a fork lift truck	Impact resistance	Weight approx.
 <p>Completely smooth for product protection extreme light weight Alu profile 6/156,8mm smooth Non moving sideprofiles This smooth profile has a balanced weight and strong proportion to make it suitable for transporting almost every product. The unique shaped seal can be pulled in the profile to avoid leakage and protect the transported product against road dirt and water splash. The seal itself is also protected by the shape of the profile. To seal both sides of the moving floor surface one double seal profile is provided. With this double seal profile the floor can be easily turned after several years, to extend the life time. This profile can be mounted on most of the plastic bearing blocks and sub decks available. The plastic bearings underneath are protected by and enclosed within the shape of the aluminum profile, this gives an excellent stability to the floor profile and is also protected against street dirt. The enormously large support and bearing surface provides an extremely long lifespan. For safe and clean emptying the trailer, all floor profiles will be sealed with an end cap in aluminum. The profiles are maintenance free, however cleaning with a high-pressure steam cleaner is permitted without any concessions. The width of the profiles is engineered so that enough space remains for two fixed side profiles in which approved cargo lashing eyes can be mounted. The profile is 100 % recyclable and keeps a certain residual value. Also available in 10 mm. The profile is NOT suitable for the transport of pallets and packaged goods by the movement of the floor.</p>	 <p>Alu profile 6/156,8mm smooth (art. no. 77.4915) Non moving sideprofiles</p>							X
 <p>A dedicated Heavy Duty profile Alu profile 8/20-156,8mm HD This profile is a so-called dedicated profile. This means that the profile is especially designed for the transport of special (mostly extreme) products. Because of the two protruding round merlons this profile has a very high impact resistance and the special round shape makes it easy to clean. Moist and dusty parts flow back into the so-called barrel shape, so moist, mud and dust can simply be drained to the outside and almost no leakage through the floor occurs. This also protects the seal. Because of the low weight a perfect payload ratio remains. The profile is NOT suitable for the transport of pallets and packaged goods by the movement of the floor.</p>	 <p>Alu profile 8/20-156,8mm HD (art. no. 79.5208)</p>							X + 310 kg
 <p>XHDI (X-treme Heavy Duty Impact) Alu profile 10/22-156,8mm XHDI This profile is a so-called dedicate profile. This means this is a profile that has been especially designed for the transport of special (mostly extreme) products. Because of the three protruding round merlons this profile has a very high impact resistance and the special round shape makes it easy to clean. Moist and dusty parts flow back into the so-called barrel shape gutters, so moist, mud and dust can simply drain to the outside and will hardly leak through the floor. This also protects the seal extra. Because of the low weight a perfect payload ratio remains. This profile is less suitable for the transport of pallets and packaged goods, these need to be loaded and unloaded with the help of a fork lift truck.</p>	 <p>Alu profile 10/22-156,8mm XHDI (art. no. 81.5440)</p>							X + 710 kg
 <p>HD SEALLESS Alu profile 11/33-156,8mm HD SEALLESS This profile is a so-called dedicate profile. This means this is a profile that has been especially designed for the transport of special (mostly extreme) products. Because of the protruding round merlons this profile has a very high impact resistance and the special round shape makes it easy to clean. Moist and dusty parts flow back into the so-called barrel shape, so moist, mud and dust can simply drain to the outside and will hardly seep through the floor. Because of the low weight a perfect payload ratio remains. This profile is NOT suitable for the transport of pallets and packaged goods, not even with the help of a fork lift truck!</p>	 <p>Alu profile 11/33-156,8mm HD SEALLESS (art. no. 83.5533)</p>							X + 730 kg
 <p>LR/LP deckslat Alu 10/133mm Leak Proof deckslat HD (Heavy Duty) This profile is specially designed for the leak proof and leak resist applications of the Cargo Floor. It fits over a full-length solid plastic bearing strip and cannot lift away. There remains a channel inbetween the moving slats to make high pressure cleaning possible. The profile can only be combined with a special T-subdeck. The total configuration of the T-subdeck, solid bearing block and this deckslat profile makes the highest resistance against high impact! It is not suitable for carrying fine materials and pallets. Also available in a 7 mm lightweight version.</p>	 <p>Alu 10/133mm Leak Proof deckslat HD (Heavy Duty) (art. no. 89.3497)</p>							Not comparable
 <p>Protected seal Alu 7/156,8mm protected seal With this special aluminium floor profile, the seal is fully protected and the high overlap of the profile over the adjacent floor profile ensures an almost complete dust/leakproof seal. This profile is therefore particularly suitable for transporting very fine and dusty products as well as products with a high moisture content. However, pallet bearers cannot be transported on this floor, nor can it be driven over with a forklift truck.</p>	 <p>Alu 7/156,8mm protected seal (art. no. 682.5841)</p>							X + 454 kg
 <p>STEEL L-Shape STEEL L-Shape This profile is specially designed for the transport of abrasive materials without compromise. Is weight not the most important issue? But the degree to which the moving floor profiles are hard-wearing is? We then recommend choosing the super strong and hard-wearing L-shape floor profile. The shape and material choice makes the L-shape the perfect solution for the transport of abrasive material. The impact resistance is also relatively high because of the shape and strength of the profile. Magnelis® preservation: this is a unique steel preservation made of zinc, magnesium and aluminium. This preservation is unique because small damages are self-healing. Because of this, this preservation is viewed as one of the best for steel.</p>	 <p>STEEL L-Shape (art. no. 954.S412)</p>							X + 879 kg



Floor seals



Optional extras

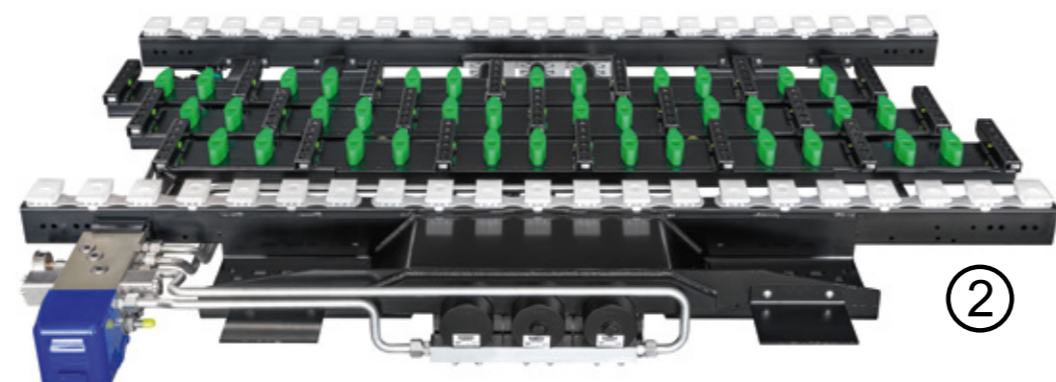
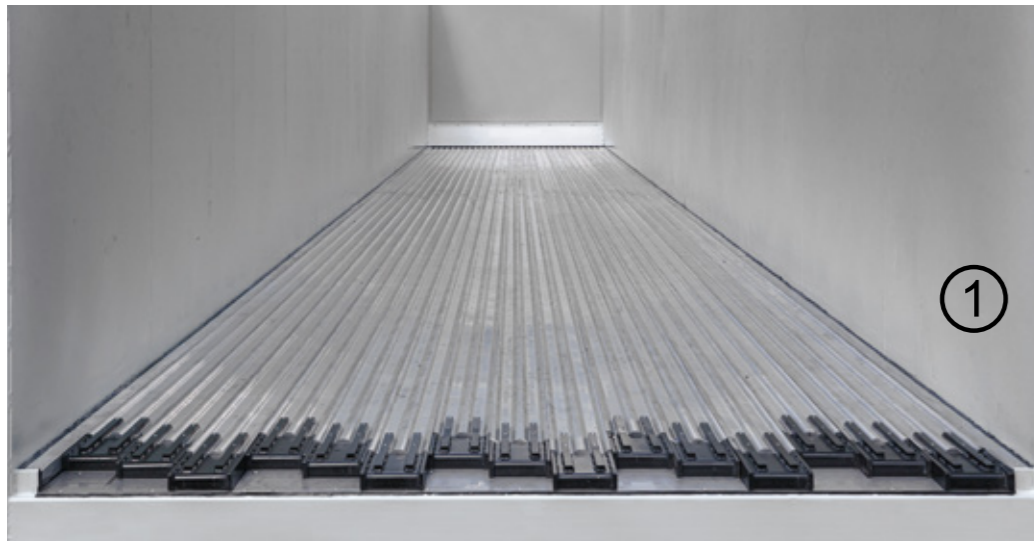

- ① Steel HD endcaps
- ② Impact Resistance Block for moving crossmember (green)
art.no. 4107061

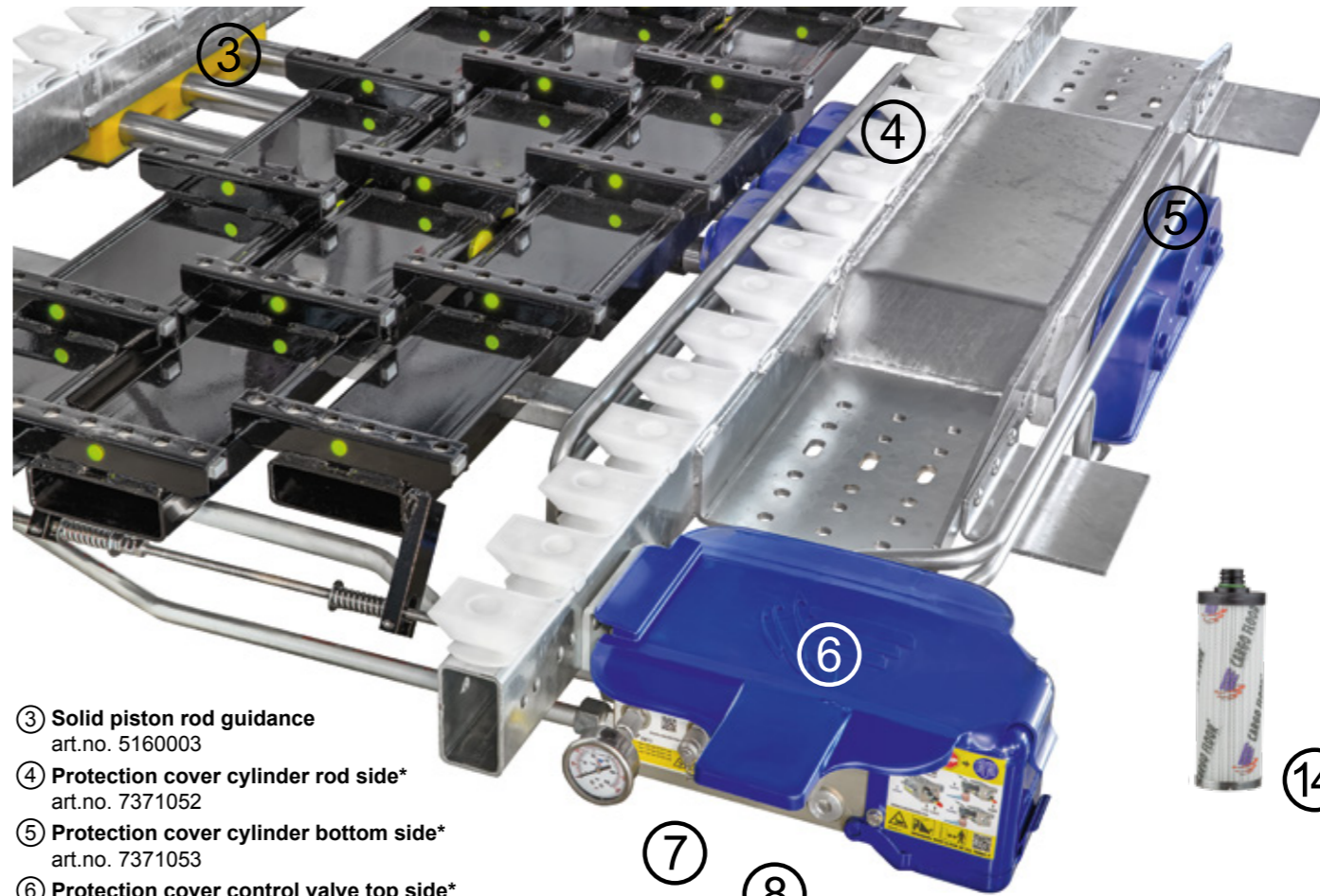

- ③ Solid piston rod guidance
art.no. 5160003
- ④ Protection cover cylinder rod side*
art.no. 7371052
- ⑤ Protection cover cylinder bottom side*
art.no. 7371053
- ⑥ Protection cover control valve top side*
art.no. 7371054
- ⑦ Pressure gauge Cargo Floor 0-250 bar
art.no. 7199003.01
- ⑧ Oil temperature safety switch
protection against overheating.
art.no. 6104024.01

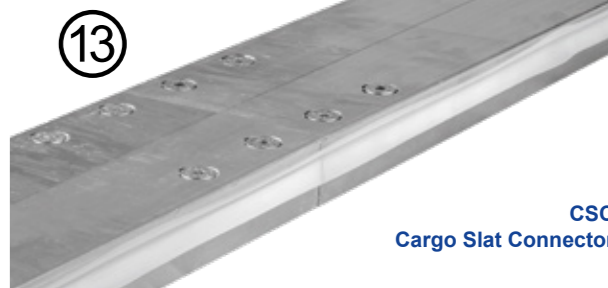

CSC
Cargo Slat Connector



Cargo Roller

Aluminum Endcaps: safe + clean
The Cargo Floor system has 45° angled endcaps that seal the floor profiles. This keeps cargo out of the floor and eliminates pinch points. No body harm (health and safety).



'Container Drive' intermodal



Drive unit: CF350-CD

This ultra-low built Cargo Floor Drive is specially designed to mount in a 20ft, 40ft or 45ft container. For intermodal applications.

The CF350-CD has the lowest built height for a drive able to carry 33t of payload. The installation can be easily done to fixate it to the existing under rail of the container with limited reinforcement. Mounting this system in a container creates a self-unloading container for when you want to haul large quantities of bulk product like household waste, wood shavings, waste paper etc. and use intermodal transportation. The containers can be put on a train to be transported to a port or incineration energy plant using readily available standard container chassis instead of dedicated trailers. For the unloading you can use either the TK-unit from the tractor unit or a standalone power pack generator.



Hydraulic drive units technical specs

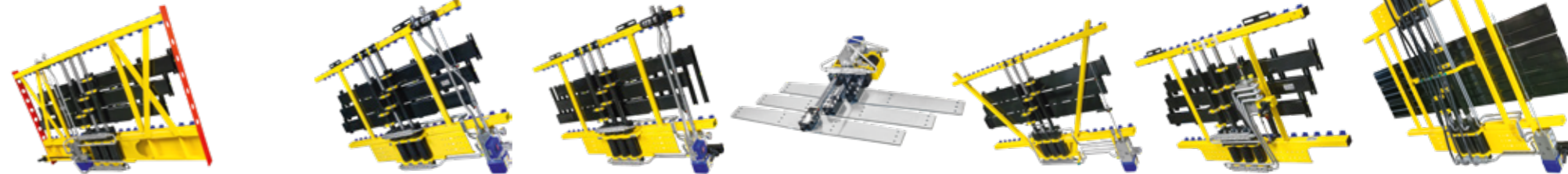

	Type	CF500 SLC Standard (HighSpeed)*	CF600 HDC	CF3LP- Speedster	CF350 CD 'Container Drive'	CF100 SLL	CF800 HD-6 cyl.
Weight (from)	kg	450 500	538	382	455	295	1038
Available in Cargo Bulkmove execution		yes (yes)*	yes	N/A	yes	yes	yes
Operating possibilities		E/B/A (B/A)*	E/B/A	B/A	E/B/A	E/B/A	E/B/A
Cylinder bore	mm	100	120	110	100	80	100
Piston rod diameter	mm	45	45	56	45	35	55
Working stroke	mm	200	200	150	200	150	200
Cylinder volume	ltr	2,82	4,2	2,48	2,82	1,36	5,3
Oil volume per cycle	ltr	8,45	12,6	7,45	8,45	4,09	16
Working pressure	bar	170	130	180	130	130	170
Max. pressure	bar	225	170	200	170	175	225
Advised oil flow per minute	ltr	110 (180)*	130	110	110	70	110
Max. oil flow per minute	ltr	130 (200)*	160	130	130	80	130
Pressure filter	µm/micron	10 (2x10)*	10	10	10	10	10
Speed at advised oil flow per minute	mtr	2,6 (4,3)*	2,1	2,2	2,6	2,6	1,4
Speed at max oil flow per minute	mtr	3,1 (4,7)*	2,6	2,6	3,1	2,9	1,6
Theoretical unloading time trailer 13.6mtr	min	6 (3)*	7	5,5	6	n/a	12
Max. loading capacity	ton	40	50	35	33	20	80
Advised pump capacity (2-line system):							
Flow per minute	ltr	110 (180)*	110	130	110	70	110
Max. pressure	bar	250	200	225	250	200	250
Pressure piping diameter	mm	20x2 (25x2)*	25x2	20x2	20x2	20x2	20x2
Return piping diameter	mm	25x2 (30x2)*	30x2	25x2	25x2	25x2	25x2
Oil tank filling at advised flow	ltr	110 (180)*	100	130	110	70	100
Oil tank filling at max. flow	ltr	130 (200)*	130	130	130	80	130
Max. oil temperature	°C	100	100	100	100	100	100

Oil types: mineral and biological (HEES); Ambient temperature ranges: ● ISO VG32 (-15 < 30 °C) ● ISO VG46 (15 < 40 °C) ● ISO VG22 (-25 < -15 °C)



About Cargo Floor

Global leading manufacturer

Cargo Floor is the global leading manufacturer of horizontal (un)loading **Moving Floor** systems. With over 30 years of experience in the industry, Cargo Floor delivers excellent quality with the very highest levels of customer service and support. **Globally recognized as a market leader**, our products are made in an ISO 9001-2015 certified manufacturing plant. Before delivery, every moving floor system is rigorously tested for function, size, and sealing to ensure that each product is easy to install by its customers and functions as designed. Cargo Floor is proudly made in the Netherlands and exported all over the world.



Innovative

We pride ourselves on our experience, working with OEMs to design and build the best possible (un)loading systems. Combining this experience with feedback from transport companies, material handling experts, and logistic managers ensures we are able to develop the most reliable, strongest, and most durable system for every application, while still being lightest moving floor system available. We strive to be the most innovative manufacturer and supplier of moving floor systems worldwide by using the very latest technology and state of the art components. All Cargo Floor drive units are powered by hydraulics and mechanically driven by internal valves to prevent contaminants like dust dirt and grime from impacting performance.

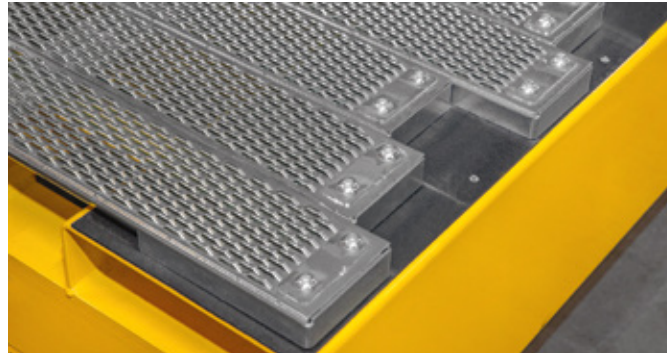

Sustainability

Everything starts with an idea.

An idea for improving and evolving the world we live in. Studying everything to perfection, because only quality generates quality. Our aim is to obtain the maximum efficiency in a simple and sustainable way in order to build a better future for next generations. We want to share our ideas with the rest of the world. Showing that “quality” and “sustainability” are two concepts that can coexist. Our idea is to protect both human being and environment, reducing risks and making the most out of what our planet gives us. We want to move beyond our borders, drawing a new path for the future. But future is closer than you think...

Cargo Floor, your future is in our world.



Cargo Floor B.V. has specialised in the following product groups:

• Cargo Floor mobile

Hydraulic moving floor systems for the transport of all kinds bulk material.

• CargoMatic “The Logistic Solution”

A dock-to-trailer conveyor system for quick, safe and fully automatically loading / unloading of all packed materials.

• Cargo Floor stationary

Hydraulic moving floor systems for self-unloading transport/dosing systems in factories (engineering, design, advice).

• Service and installation



Cargo Floor B.V.
Byte 14
7741 MK COEVORDEN
The Netherlands
☎ +31 524 593 900

✉ info@cargofloor.com

Cargo Floor USA, Inc.
Texarkana
Texas
USA

🌐 cargofloor.com



WORLDWIDE SERVICE NETWORK